

**Rinnai**

Operation and installation guide

---

# Hotflo hot water heat pump

Model: EHP32



# Important:

This appliance shall be installed in accordance with:

- Manufacturer's installation instructions
- Local regulations and municipal building codes

Installation, servicing and repair shall be carried out only by authorised personnel.

Installer, please leave this manual with the customer for future reference.

## **Warning**

Improper installation, adjustment, alteration, service or maintenance can cause property damage, personal injury or loss of life.

---

For more information about buying, living and servicing of Rinnai appliances call: 0800 RINNAI (0800 746 624)

Rinnai New Zealand Limited  
105 Pavilion Drive, Mangere, Auckland  
PO Box 53177, Auckland Airport, Auckland 2150

Phone: (09) 257 3800, Fax: (09) 257 3899  
Email: [info@rinnai.co.nz](mailto:info@rinnai.co.nz)  
Web: [www.rinnai.co.nz](http://www.rinnai.co.nz), [youtube.com/nz](https://www.youtube.com/nz)



# contents:

Suitability	4
Warning about hot water	5
Safety information	6
How it operates	7
Turning the system off and on	8
General information	9
Troubleshooting guide	10
Specification	11
Dimensions and clearances	12
Heat pump checklist	13
Connecting to a storage tank	14
Attaching the temperature sensor	15
Piping	16
Filling and commissioning	17
Protection against freezing	18
Handover to the customer	18
Draining instructions	19
Limited warranty	20
Installer details	22
Proof of purchase	23

# Suitability

Suitable for:

- external domestic applications
- connection to mains pressure hot water cylinders
- NZ geographical zones 1 and 2 only, refer map below

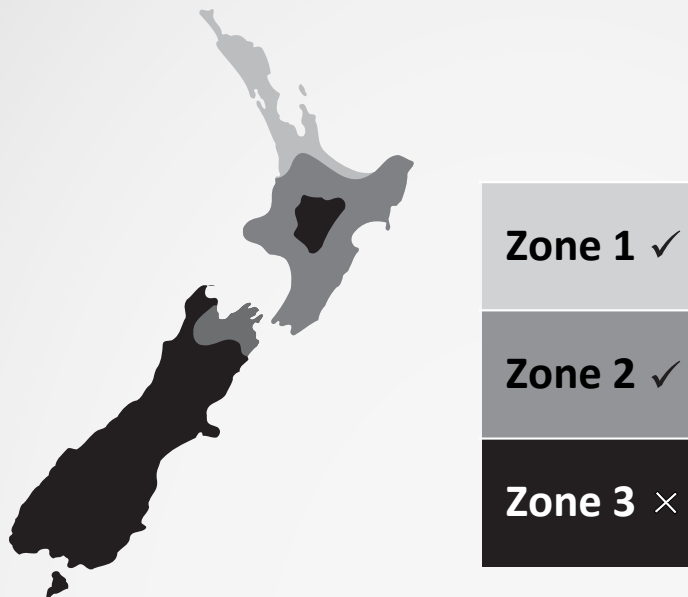

Not suitable as a spa or swimming pool heater.

## Water quality

Not suitable for certain water chemistries. For further information, refer to the warranty information at the back of this guide.

## Geothermal hot spots

The Rinnai Hotflo hot water heat pump is not warranted against corrosion in geothermal areas such as Rotorua, where high levels of sulphur dioxide are present in the atmosphere.

## Distance between the heat pump and storage tank



If the heat pump and storage tank are more than 5 m apart an R5043 adjustable flow restrictor must be purchased as a separate item to complete installation.

# Warning about hot water



Water temperatures above 55 °C can cause instant severe burns, such as scalding and may even result in death. Those most at risk; children, disabled, elderly, and the sick. Hot water at 65 °C, a common water temperature in New Zealand, can severely burn a child in less than half a second. At 55 °C it takes half a minute.

## Always

- Test the water temperature with your elbow before placing your child in the bath and feel the water yourself before bathing or showering
- Supervise children whenever they are in the bathroom
- Make sure the hot water tap is turned off

## Consider

Installing child proof tap covers or child resistant taps, both will prevent a child being able to turn on the tap.

## Never

Leave a toddler in the care of another child. They may not understand the need to have the water temperatures set at a safe level.

# Safety information



This appliance is not intended for use by persons (including children) with reduced physical, sensory or mental capabilities, or lack of experience and knowledge, unless they have been given supervision or instruction concerning use of the appliance by a person responsible for their safety.

## Supervise children

Children should be supervised to ensure they DO NOT play with the appliance.

## Never use flammable sprays

Never use a flammable spray such as hair spray, lacquer, paint etc. near this unit as this may cause a fire.

## Electrical

Access covers of the water heating system components conceal 230 V wiring and must only be removed by an authorised person.

The power lead from the heat pump must be plugged into an external weatherproof electrical outlet. If the power supply cord is damaged, it must be replaced by an authorised person in order to avoid a hazard, using a genuine replacement part available from Rinnai. Take care not to touch any power plugs with wet hands.

## Pipe work may be hot

Care should be taken not to touch the pipe work as it may be hot.

## DO NOT

Do not:

- Place articles on or against this appliance
- Store chemicals or flammable materials near this appliance
- Operate with the panels or covers removed from this appliance
- Activate the heat pump unless the tank is full of water
- Insert fingers or objects into the air inlet/outlet—when the fan is rotating at high speed it can cause an injury

# How it operates

The heat pump operates by transferring the energy from the ambient outside air into the water. Electricity is used to operate the system, but not to heat the water, so less electricity is used.

The Rinnai hot water heat pump is made up of two separate components; a heat pump and a water storage tank. The heat pump unit includes a circulation pump which draws water from the storage tank and returns it to the tank at a higher temperature. A temperature sensor in the tank is used to control the heat pump operation.

**Rear of heat pump unit**

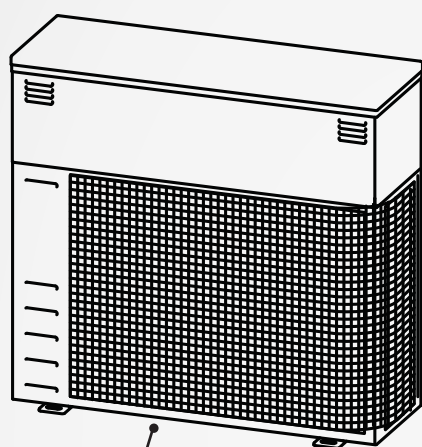

Inlet ambient air

**Front of heat pump unit**

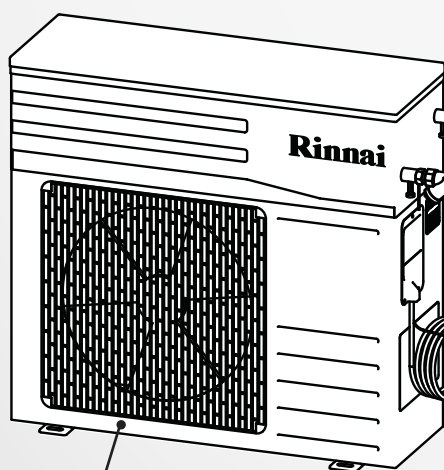

Outlet air

Water from heat pump  
to storage tank

Storage tank  
temperature  
sensor lead

Water from storage  
tank to heat pump

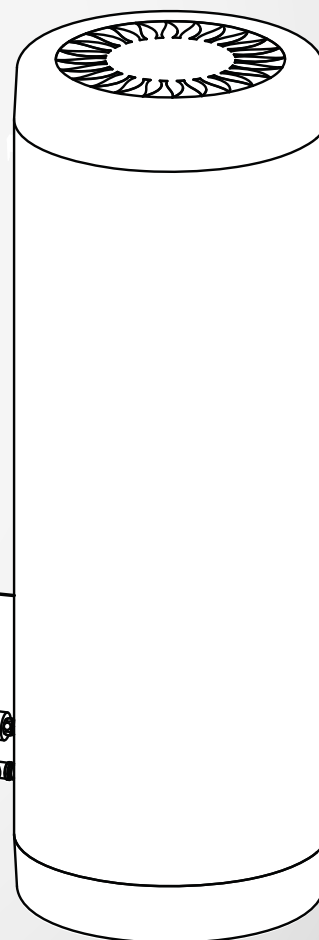

# Turning the system off and on

## Turning the water heating system off

If you plan to be away for only a few nights, we suggest you leave the water heating system switched on. If it is necessary to switch it off, switch off the electric power supply to the heat pump unit.



Do not turn the power off to the heat pump unit if snow or frost conditions are expected as components in the system may be damaged by freezing. If power needs to be turned off, or power failure occurs and freezing conditions are expected, the water needs to be drained from the heat pump unit, this must be carried out by an authorised person. It is not necessary to drain the storage tank.

## Turning the water heating system on

Switch on the electric supply to the heat pump unit. Water heating will now occur as required. It may take a number of hours before hot water is available.



# General information

## **Defrosting function**

The heat pump has an inbuilt defrosting function. This requires power to prevent damage in freezing conditions. DO NOT disconnect the power if there is a likelihood of freezing without draining the unit.

## **Draining and filling**

Draining and filling of the complete system normally only occurs during installation or servicing and must be carried out by an authorised person.

Draining water from the heat pump unit is necessary if the power will be shut off to the unit, and snow or frost conditions are expected (it is not necessary to drain the storage tank). Arrange for an authorised person to carry out this task.

## **Servicing**

Rinnai has a maintenance/service and spare parts network with personnel who are fully trained and equipped to give the best advice on your Rinnai appliance. If your system needs maintenance and/or servicing, please call Rinnai (0800 746 624) from a land line and select option one for a service centre in your area.

For reliable operation Rinnai hot water systems should be serviced every two years. Regular maintenance and servicing is not covered by the Rinnai warranty.

Do not attempt to carry out any work on your system other than that mentioned in the troubleshooting section. If you have any faults or problems, contact your installer or call Rinnai.

# Troubleshooting guide

## Lack of hot water, or no hot water

### Is there electricity supply to the heat pump?

Check that the heat pump is plugged into the power point and turned on—the compressor will start approximately three minutes after the power is turned back on.

Check that the isolating switch marked 'Hot Water' or 'Water Heater', at the meter box, is switched on. Check also any isolating switches installed near the water heater are switched on.

Check the fuse or circuit breaker marked 'Hot Water' or 'Water Heater' at the meter box. Repeated failure of the fuse or tripping of the circuit breaker indicates a fault that must be investigated by an authorised tradesperson.

### Are you using more hot water than you think?

Often you don't realise how much hot water is actually being used, especially when showering. Typical flow rates for showers is around 8-10 litres per minute. Conduct a simple experiment by placing a measured bucket under your shower for ten seconds and multiply by six to obtain the amount of water produced over a minute.

If your result is significantly more than the rates above, you may want to consider installing flow restrictors. These are available at all good plumbing outlets.

### Cold water relief valve discharging continuously?

It is normal for the cold water relief valve to discharge a small quantity of water through the drain line while the heat pump is operating to heat the water. If water is discharging continuously when the heat pump is not operating, there may be a fault with one of the valves—contact your installer to discuss.

## High electricity bills

If you think your electricity bill is too high, check:

- The electricity tariff on your last bill, has this changed from previous bills?
- If the cold water relief valve is discharging continuously.
- Water usage, has this increased (guests, winter etc.)
- Temperature probe/sensor is installed as per instructions on page 15.

# Specification

<b>System specifications</b>	<b>Rinnai split heat pump water heater: Model EHP32</b>	
Max. pipe length between heat pump & storage tank (installer to supply)	For each pipe	Refer page 16
EHP32 heat pump unit	Rated input	1.9 kW
	Max. water pressure	850 kPa
	Max. energy output (this is the max. possible from the unit and should be used to ensure tank TPR valve is suitably sized)	6.0 kW
	Refrigerant type/mass	R134A/750 g
	Ingress protection	IP24
	Net weight	60 kg
	Noise level	Fan approx. 55 dB(A)
	Power supply	240 V, 50 Hz
	<b>Start up protection</b> When the power is first turned on to the heat pump or when power is cut then restored, the unit will not start for three minutes, this is to protect the compressor.	
<b>Ambient temperature operating range (-7 to 45 °C)</b> When the ambient temperature is below 2 °C the tank temperature achieved may be lower. When the ambient temperature is high, the air supply fan will run at a lower speed.		
<b>Defrosting function</b> The heat pump has protection systems that will stop the operation of the unit if; the air inlet/outlet is blocked, voltage is out of nominal range (207-255 V), over pressure or over temperature in the refrigerant system.		
<b>Refrigerant compressor oil</b> Type: Neo 32, quantity: 520 ml		

## **Cylinder settings**

Pressure Limiting Valve (PLV)	500 kPa
Cold water pressure relief	700 kPa
Temperature & Pressure Relief Valve	850 kPa

### Please note:

Installer may need to change the existing valves on the cylinder to meet these kPa ratings

# Dimensions and clearances

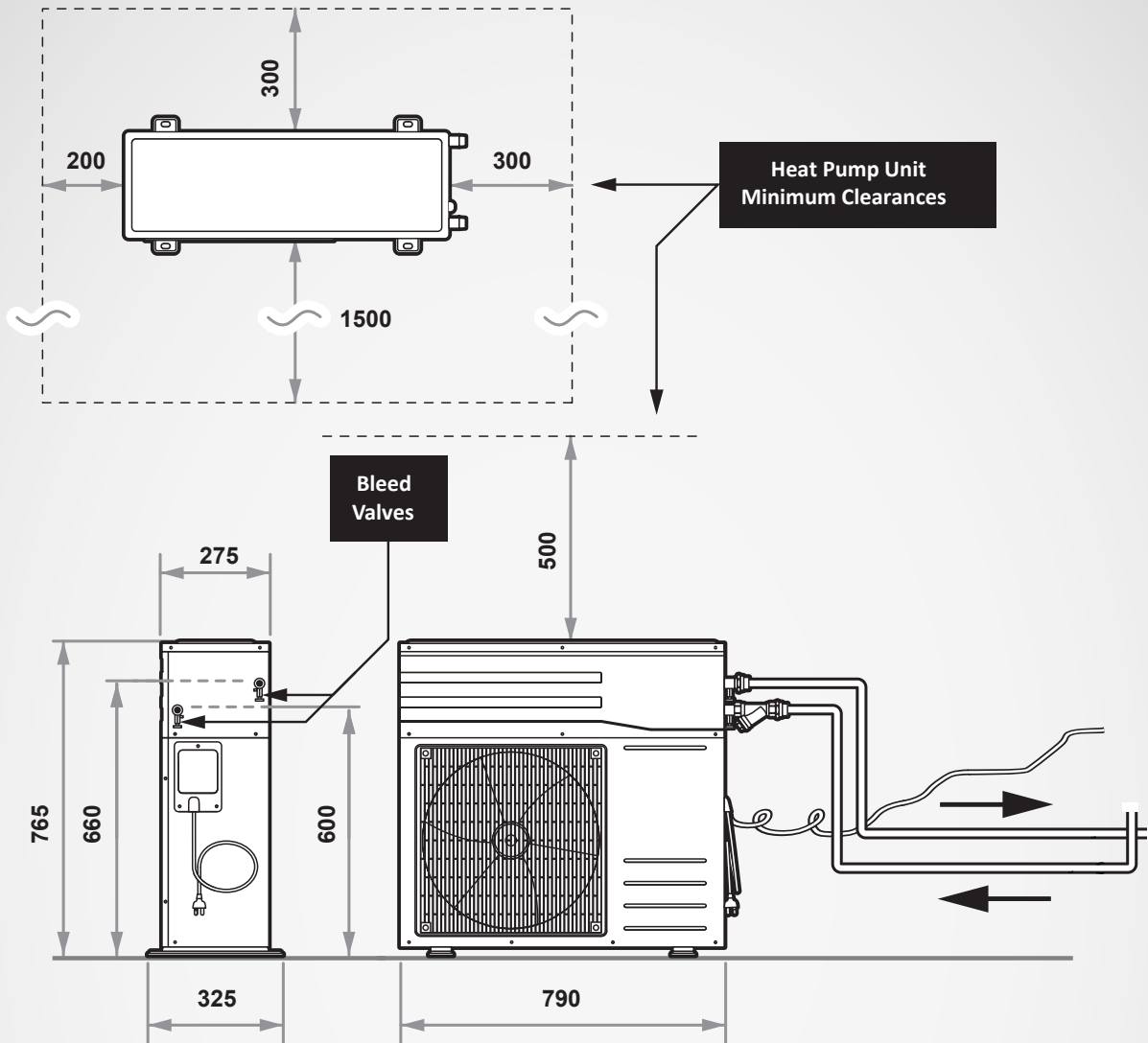



# Heat pump checklist

- Minimum clearances maintained for correct operation and access.
- 500 mm clearance above the unit.
- Suitably drained catch pan installed where leakage could cause damage.
- Positioned in a location where noise from operation will not disturb occupants or neighbours, particularly overnight.
- 10 A weatherproof 3-pin socket installed within 1.5 m of the connection of the heat pump.
-  DO NOT hard wire this appliance. Costs associated with disconnecting from hard wiring are not covered by warranty.
- Temperature sensor cable run between the heat pump and storage tank. The supplied cable has a length of 9.5 m.
- Maximum water pressure is 850 kPa.
- If water drips from the compressor are not acceptable, a plastic drain elbow (supplied) is fitted to the bottom of the unit (as shown below), and a drain line is installed and run to a suitable disposal point.

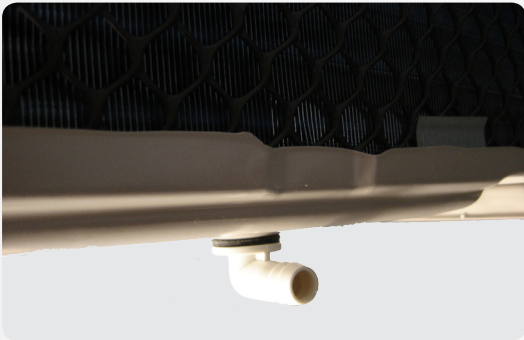

- Storage tank valves and water temperature delivery must be in accordance with G12/AS3500.
- Heat pump and tank less than 5 m apart**
- Supplied flow restrictor installed at heat pump outlet, and pump set to speed 3.
- Heat pump and tank greater than 5 m apart**
- Rinnai part number R5043 flow restrictor installed and adjusted to 3 litres per minute with a suitable pump speed.

# Connecting to a storage tank

## Connecting to a Rinnai Hotflo storage tank

The riser and dip tubes in the Hotflo storage tank need to be positioned to suit the installation using the dip tube tool (purchased separately, part number 11143). Insert the tool into the dip or riser tube to be reversed and rotate 180°.

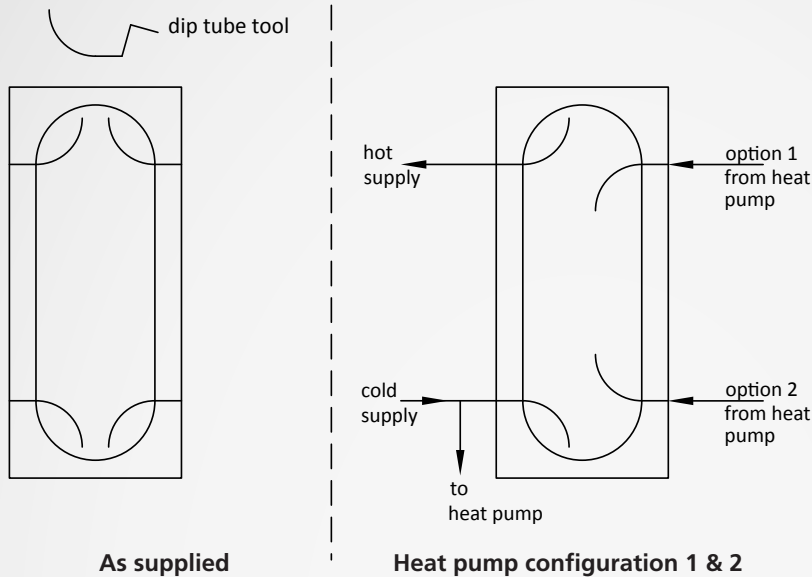

## Connecting to other storage tanks

Connections to storage tanks which are not heat pump or solar ready can be made in a number of ways—some examples are shown below.

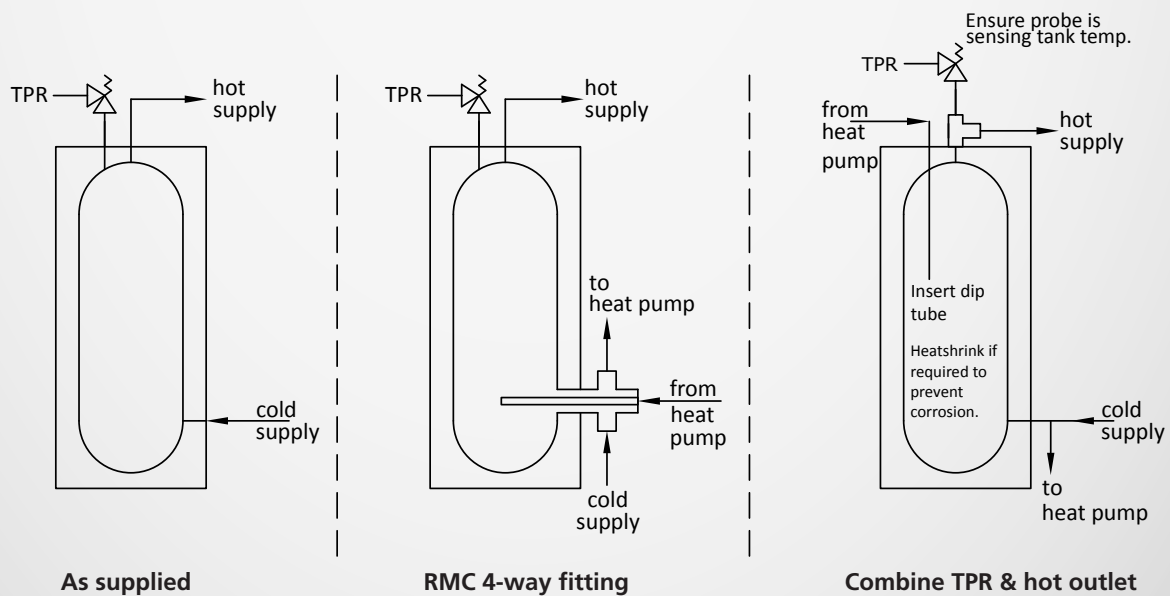

# Attaching the temperature sensor



The temperature sensor lead (supplied) must be run from the heat pump to the storage tank.

Ensuring and maintaining a good temperature probe contact with the storage tank will ensure accurate temperature readings. Failure to install the temperature probe/sensor as instructed could cause the heat pump to run for longer periods, and result in high electricity bills for the customer.

1. Remove the element box cover from the storage tank.
2. Apply a small quantity of a suitable heat transfer compound, such as Unick (available from Dick Smith electronics) along the back of the temperature probe and contact fixing.



3. Place the temperature probe as high up inside the element box as possible, and run the sensor cable down the side of the element box.

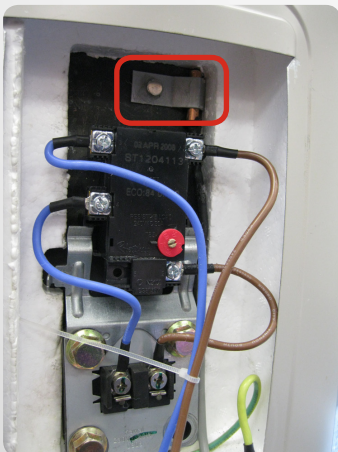

4. Cover all components in the element box with the insulation provided, and refit the element box cover.



5. Remove the electrical cover plate from the right hand side of the heat pump. Plug the other end of the temperature sensor into the matching connector. Refit the cover plate.
6. Run the temperature sensor over the required length and fix in place with suitable clips. Gather any excess cable and secure with cable ties in a convenient position.

# Piping

Pipes must be insulated with ultraviolet and weather resistant closed cell insulation having a minimum thickness of 13 mm and thermal conductivity of greater than 0.045 W/m.K. Examples; Armacell HT and Armaflex.

1. Attach the supplied water filter to the heat pump water inlet.
2. Fit suitable isolating valves to the heat pump connections at the tank.



Costs associated with draining storage tanks to service the heat pump, where valves are not fitted, are not covered by warranty.

3. Select pipe size with reference to the table below. Maximum pipe length is the total pipe installed (e.g. 14 m would be 7 m flow plus 7 m return).

<b>Pipe inner diameter</b>	<b>Maximum pipe length</b>
12 mm	14 m
15 mm	22 m
19 mm	30 m



# Filling and commissioning

1. Fill the storage tank and heat pump until water flows freely from the outlets in the house.
2. Bleed the air from the heat pump and prime before starting the heat pump.



Failure to bleed all air from the heat pump can lead to failure of the circulation pump. This is not covered by warranty.

3. Open shut-off valves SV1 and SV2. Open bleed valves BV1 and BV2. Once the water is running from the drain hoses attached to BV1 and BV2 (without air bubbles), BV1 can be closed followed by SV1.
4. Once water (without air) is running from the BV2 drain, close BV2.
5. Close SV2 and open SV1. Open BV1. Once water is running from the BV1 drain (without air), close BV1. Open SV2.

6. Remove the top cover from the heat pump.
  - Identify the mains voltage connections and take care to avoid them.

7. Plug in the heat pump power supply. The LED display on the PCB will display the current temperature reading of the temperature sensor. After three minutes delay, operation will commence.

8. Open the central bleed screw on the pump housing briefly to remove any remaining air from the heat pump.

9. Allow the heat pump to run for at least 15 minutes to verify it is operating correctly. If operation ceases and P1 is displayed on the LED, this indicates water circulation is not sufficient and the priming process must be repeated.

10. If the heat pump and tank are more than 5 m apart and the R5043 adjustable flow restrictor is fitted, adjust the pump speed and flow restrictor to achieve a 3 litre per minute circulating flow.

11. Replace the top cover of the heat pump.

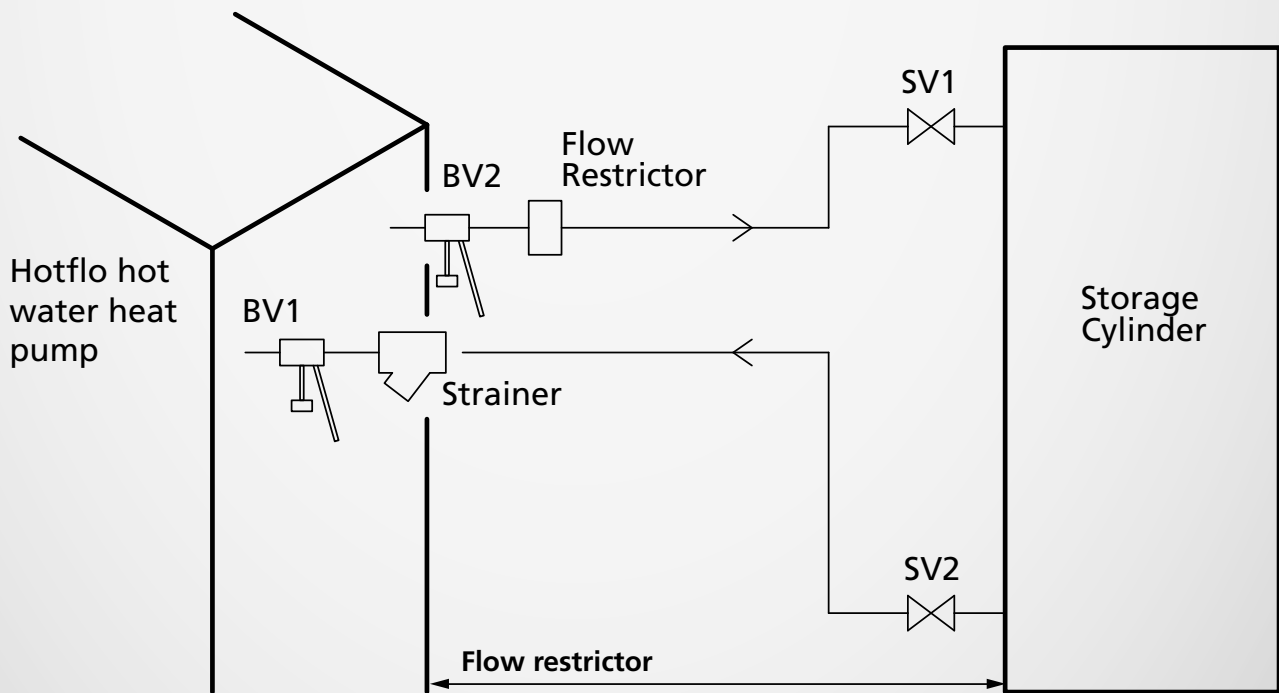

- ≤ 5 m use 3.5 mm brass orifice supplied
- > 5 m use R5043 adjusted to 3 L/min

# Protection against freezing

Supplied with this guide are two labels warning against disconnecting the power supply where freezing conditions are likely. These should be fixed adjacent to the heat pump outdoor power point and on the main fuse/switchboard of the house.

# Handover to the customer

After testing is completed, explain to the householder the functions and operation of the heat pump water heater system.

Explain to the householder the need to drain the heat pump if power is likely to be shut off and if freezing conditions could occur. Also explain to the householder the importance of carrying out maintenance in accordance with this manual.

Leave this guide with the householder.

# Draining instructions

## Draining the heat pump unit

1. Turn off the power to the heat pump.
2. Close the cold water mains supply stop cock.
3. Close the isolation valves between the cylinder and heat pump.
4. Disconnect the piping from the heat pump as shown and allow the water to drain from the pipes.
5. Reconnect the pipe work, but do not open the isolation valves until the heat pump is ready to be refilled.

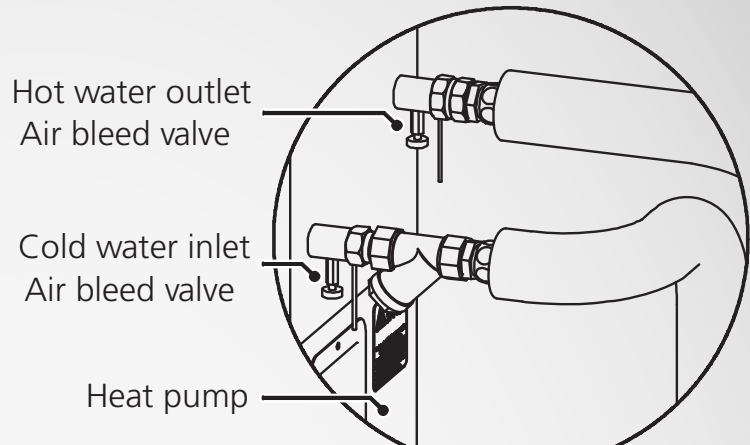

Draining the heat pump - step 4

## Draining the heat pump unit and tank

1. Turn off the power to the heat pump.
2. Close the cold water mains supply stop cock.
3. Ensure any isolating valves between the heat pump and the cylinder are open.
4. Open a hot tap to relieve pressure.
5. Disconnect the hot outlet near the top of the tank.
6. Disconnect the cold inlet near the bottom of the tank.

The system will now drain completely.



**IMPORTANT**

To avoid water damage to the heat pump and/or tank, ensure water is able to drain freely away from both appliances.

# Limited warranty

## Rinnai warranty summary

HOTFLO HOT WATER HEAT PUMP

	Compressor	All other components
<b>Parts</b>	3 years	3 years
<b>Labour</b>	3 years	3 years

All terms of the warranty are effective from the date of installation of the Rinnai Hotflo Heat Pump. Proof of installation will be required.

### General warranty terms

Rinnai reserves the right to make modifications and change specifications and its parts without notice.

For the purposes of the Consumer Guarantees Act 1993, Rinnai only guarantees the availability of repair facilities and spare parts for the express warranty periods recorded in the Rinnai warranty summary table.

If the Rinnai Hotflo Heat Pump is being acquired for personal, domestic or household use, this warranty does not limit any consumer rights or guarantees that may apply under the Consumer Guarantees Act 1993. If the product is being acquired for the purposes of a business, the provisions of the Consumer Guarantees Act 1993 do not apply and no other warranties (either express or implied by law) apart from those stated in this warranty apply.

### Warranty terms and conditions

All terms of this warranty are effective from the date of installation. The attending service person reserves the right to verify this date.

All Rinnai appliances must be installed, commissioned, serviced, repaired and removed in accordance with the manufacturer's instructions,

local regulations, and municipal building codes by persons authorised by local regulations to do so.

All appliances must be operated and maintained in accordance with the manufacturer's operating instructions.

The warranty applies only to the components supplied by Rinnai. It does not apply to components supplied by others, such as, isolating valves, electrical switches, pipe work, electrical cables, fuses, and where applicable components supplied by others, but not limited to these.

Where the appliance has not been sited in accordance with the installation instructions or installed such that normal service access is difficult, a service charge will apply. If at the discretion of the attending service person the installation is deemed illegal or access is dangerous, service will be refused. Any work required to gain access to the appliance will be chargeable by the attending service person (for example, removal of walls, or the use of special equipment to move components, but not limited to these).

Where a failed component is replaced under warranty, the balance of the original appliance warranty will remain effective. The replacement part or appliance does not carry a new warranty.

Rinnai reserve the right to transfer functional components from defective appliances if they are suitable.

Rinnai reserve the right to have the installed product returned to the factory for inspection.

Where the heat pump is installed outside the metropolitan area or further than 40 km from a Rinnai authorised service centre,

travel costs shall be the owner's responsibility.

### Warranty exclusions

The following exclusions may cause the warranty to become void and will result in a service charge and costs of parts (if required).

- Accidental damage and acts of God.
- Failure due to abuse or misuse, improper maintenance or improper storage.
- Failure due to incorrect or unauthorised installations.
- Failure or damage caused by alterations, service or repair work carried out by persons other than a Rinnai service person or service centre.
- Where the heat pump has failed directly or indirectly as a result of poor water quality outside the limits specified.
- Where it is found that there is no fault with the appliance and the issue is related to the installation or is due to power failure.
- Subject to any statutory provisions to the contrary, Rinnai does not accept:
  - a. liability for consequential damage or any incidental expenses resulting from any breach of the warranty
  - b. claims for damage to buildings or any other consequential loss either directly or indirectly due to leaks from the heat pump or any other faults



## Water quality

Water quality outside the limits, as set down below, will void this warranty. Water quality tests must be carried out at the customer's own cost. Rinnai will reimburse any reasonable test costs where water quality is within the limits tabled.

### Water quality and impurity limits

<b>TDS (Total Dissolved Solids)</b>	<b>Total Hardness CaCO<sub>3</sub></b>	<b>Alkalinity (as CaCO<sub>3</sub>)</b>	<b>Dissolved (free) CO<sub>2</sub></b>	<b>pH</b>	<b>Chlorides</b>	<b>Magnesium</b>	<b>Sodium</b>	<b>Iron</b>	<b>Langelier Index</b>
Up to 600 mg/L or ppm	Up to 200 mg/L or ppm	Up to 200 mg/L or ppm	Up to 25 mg/L or ppm	6.5-8.5	Up to 300 mg/L or ppm	Up to 10 mg/L or ppm	Up to 150 mg/L or ppm	Up to 1 mg/L or ppm	Between -1.0-0.8

Most metropolitan water supplies fall within these limits. If you are unsure about water quality, please contact Rinnai and we will provide you with details of an authorised agency able to test your water for compliance to Rinnai standards. If sludge or foreign matter is present in the water supply, a suitable filter should be incorporated in the water supply. Some examples of water quality issues where water may need to be treated:

- Hard water (areas including Wanganui)
- Aggressive water (areas including Christchurch)
- Both hard and aggressive water (some bore water)

# Installer details

Company name:

---

Installer name:

---

Address:

---

---

Phone:

---

Mobile:

---

Signed:

---

Date:

---

# Proof of purchase

RECORD YOUR DETAILS  
OF PURCHASE BELOW:

ATTACH YOUR PROOF OF  
PURCHASE HERE:



Retailer:

Retailer address:

Date of purchase:

Product details:

Please keep these details in a safe place for future reference.



Experience our innovation

**Rinnai.co.nz | 0800 746 624**

<http://www.youtube.com/rinnainz>